

FUJIFILM



FUJI MEDICAL DRY IMAGER

DRYPIX

Lite (Model : DRYPIX 2000)

Outstanding performance, remarkable efficiency and superb quality satisfy your medical imaging needs



- A New Concept Tabletop Dry Imager
- Supports Multiple Film Size
- Expandable to Two Magazines



www.futuremed-tr.com

:+(90) 533 784 42 95

Fuji Medical Imager DRYPIX Lite Specifications

Basic Specifications

Standard Component:	Fuji Medical Dry Imager DRYPIX Lite (Model: DRYPIX 2000)
Recording method:	Thermal head transfers heat while in contact with thermal film
Applicable film:	Fuji Medical Dry Film DI-HT 35 x 43 (14 x 17), 26 x 36, 25 x 30 (10 x 12), 20 x 25 (8 x 10)
Film loading:	Daylight film loading
Film magazines:	Up to 2 magazines
Processing capacity:	Approx. 50 sheets/hour 35 x 43 (14 x 17), Approx. 75 sheets/hour 26 x 36, Approx. 65 sheets/hour 25 x 30 (10 x 12), Approx. 90 sheets/hour 20 x 25 (8 x 10)
Pixel size:	84.7µm (300dpi)
Recording gradation:	12 bits
Image memory:	1 GB
Density adjustment:	Automatic
Input channels:	DICOM network input x1 channel only

Physical Characteristics

External dimensions (W x D x H):	530 x 590 x 365mm (21 x 23 x 14") with Large magazine/ 530 x 470 x 365mm (21 x 19 x 14") with Small magazine 180mm higher with optional sheet-feeder unit
Weight:	32 kg (71 lbs.) / 43 kg (95 lbs.) with optional sheet-feeder unit
Power supply:	Input voltage: AC100-240V / Phase: Single / Frequency: 50-60Hz Rated current: 5-2A

Operating Environment

Temperature:	15-30°C
Humidity:	40-70% RH (at 15°C) to 15-70% RH (at 30°C) (no dew condensation)

Options

- Optional sheet-feeder unit (*Supply magazine not included [Purchase separately])
- Vehicle mounting kit •Cart (*Cart does not conform to UL requirements.)
- Large magazine •Small magazine

*DRYPIX Lite doesn't come standard with supply magazine. Purchase magazine accordingly.
 *Large magazine can only accommodate 35 x 43 (14 x 17) film size.
 *Small magazine can accommodate either 26 x 36, 25 x 30 (10 x 12) or 20 x 25 (8 x 10) film size.
 To set up the film size to your desired size requires the support of our servicing personnel.
 Once the magazine is set to a film size, you cannot change it to a different one by yourself.
 *Film sizes indicated above required the respective magazines, as desired.

Dimensions

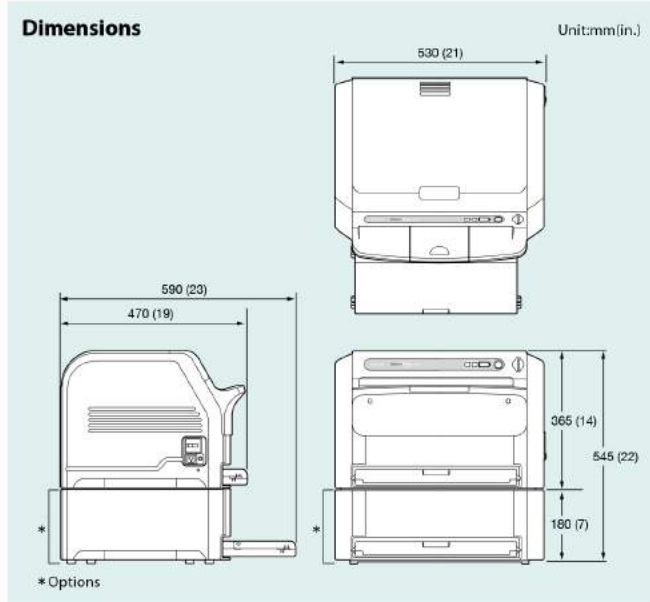

Consumables

Fuji Medical Dry imaging Film DI-HT



*DI-HT only for DRYPIX Lite.

- 35 x 43 (14 x 17): 100 sheets/pack
- 26 x 36: 100 sheets/pack
- 25 x 30 (10 x 12): 100 sheets/pack
- 20 x 25 (8 x 10): 100 sheets/pack



DRYPIX Lite shown optional sheet feeder unit and 2magazines

Specifications are subject to change without notice.
 All brand names or trademarks are the property of their respective owners.
 In some countries, regulatory approval may be required to import medical devices.
 For the availability of these products, please contact your local sales representatives.

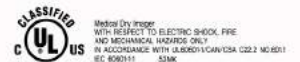

FUJIFILM

FUJIFILM Corporation

<http://www.fujifilm.com/products/medical>

FUTUREMED

Tel : +(90) 212 210 21 42

Mobile/WhatsApp : +(90) 533 784 42 95

email : info@futuremed-tr.com

Halil Rifat Paşa Mah. Yüzer Havuz sk.

Perpa Ticaret Merkezi B Blok Kat.5

NO:184 Şişli / İstanbul / Turkey